

# KOMATSU®

## PC210-8

## PC210LC-8

## PC210NLC-8

NET HORSEPOWER  
110 kW 148 HP @ 2.000 rpm

OPERATING WEIGHT  
PC210-8: 21.390 - 21.930 kg  
PC210LC-8: 21.990 - 22.850 kg  
PC210NLC-8: 21.830 - 22.460 kg

BUCKET CAPACITY  
max. 1,68 m<sup>3</sup>

**PC**  
**210**

HYDRAULIC EXCAVATOR



**PC210/LC/NLC-8**

**ecot3**

# WALK-AROUND

## A unique machine with unrivalled benefits

The PC210-8 is a rugged, productive, all-European machine. Designed and expressly built for European markets, it delivers outstanding productivity, reliability and operator comforts in a robust, environmentally friendly package. Komatsu's exclusive, on-board, HydraMind system assists in all operations, providing enhanced machine performance that's always perfectly matched to the task.

### ***Improved fuel consumption***

Through total Komatsu development and control of the engine, hydraulic and electrical systems.

**Up to 10% improvement!**



**KOMTRAX**

### ***Komatsu Tracking System***

Track and monitor your machine anytime,  
anywhere for total peace of mind.

### ***Low-noise cab***

Operator ear noise is as low as an average passenger car.

**NET HORSEPOWER**  
110 kW 148 HP

**OPERATING WEIGHT**  
PC210-8: 21.390 - 21.930 kg  
PC210LC-8: 21.990 - 22.850 kg  
PC210NLC-8: 21.830 - 22.460 kg

**BUCKET CAPACITY**  
max. 1,68 m<sup>3</sup>

### **Large TFT monitor**

Improved operator interface through  
Komatsu-developed information technology.  
(TFT: Thin Film Transistor)

### **New, safe SpaceCab™**

Tubular design developed specifically for  
hydraulic excavators to protect the operator  
in the event of a roll over accident.



**ecot3**  
ecology & economy - technology 3

The Komatsu SAA6D107E-1 engine  
meets EU Stage IIIA and EPA Tier III  
emission regulations.

**29% NOx reduction.**

# NEW, SAFE SPACECAB™

Specifically developed for Komatsu excavators, the new cab is designed with a tubular steel frame. The framework provides high durability and impact resistance with very high impact absorbancy. The seat belt keeps the operator in the safety zone of the cab in the event of a roll over.

## Wide, spacious cab

The newly designed, wide and spacious cab includes a heated air suspension seat with reclining backrest. The seat height and longitudinal inclination are easily adjusted using a pull-up lever. You can also set the operational posture of the armrest and the position of the console to suit your needs. Reclining the seat further enables you to place it into the fully flat state with the headrest attached.

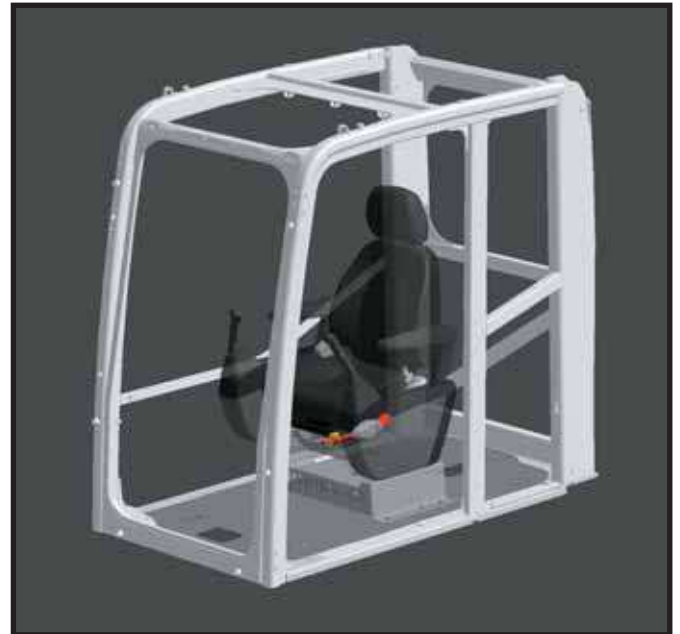

## Low-noise design

The newly designed cab is highly rigid and has excellent sound absorption ability. Thorough improvement of the noise source reduction technology and the use of low-noise engine, hydraulic equipment and air conditioner mean this machine generates very low noise levels, similar to that of a passenger car.

## Pressurised cab

An air conditioner and air filter are fitted as standard. Together with a higher internal air pressure (60 Pa), they reduce dust entry into the cab.

## Low vibration with cab damper mounting

A multi-layer viscous mount system incorporates a longer stroke and the addition of a spring. The new cab damper mounting combined with a high-rigidity deck reduces vibration at the operator's seat.

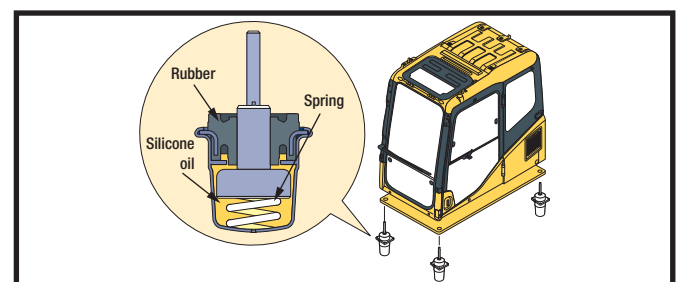



**Automatic air conditioner**  
Enables you to easily and precisely set cab atmosphere with the instruments on the large LCD. The bi-level control function keeps the operator's head and feet cool and warm respectively. The improved air flow keeps the inside of the cab comfortable throughout the year. The defroster function keeps the front glass clear.

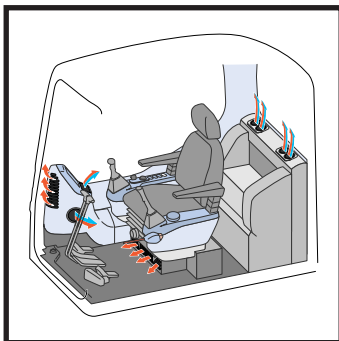

**Defroster/demister**



**Large sun roof with integrated sun shade**



**Outer air filter**  
Easy removal/installation of the air conditioner filter element, without tools facilitates cleaning.

**3-button lever**

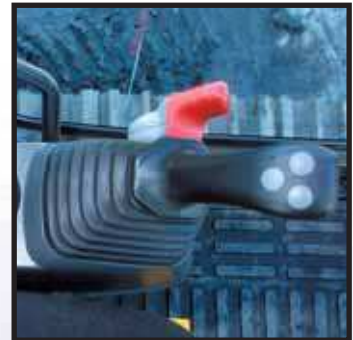

**Hot and cool box**



**Bottle holder and magazine rack**



**12 Volt power supply**



**Radio**



# NEW, LARGE TFT MONITOR

## EMMS (Equipment Management and Monitoring System)

The EMMS is a highly sophisticated system, controlling and monitoring all the excavator functions. The user interface is highly intuitive and provides the operator with easy access to a huge range of functions and operating information.

### Large multi-lingual TFT monitor

A large user-friendly color monitor enables safe, accurate and smooth work. Screen visibility is improved through a TFT liquid crystal display that can be easily read at various angles and in various lighting conditions.

- Simple and easy-to-operate switches
- Industry first function keys facilitate multi-function operations
- Displays data in 10 languages to support operators around the world

### On-screen symbols

- 1 Auto deceleration
- 2 Working mode
- 3 Travel speed
- 4 Engine water temperature gauge
- 5 Hydraulic oil temperature gauge
- 6 Fuel level gauge
- 7 Eco-gauge
- 8 Function switch menu

### Basic operation switches

- 1 Auto deceleration
- 2 Working mode
- 3 Travel speed
- 4 Buzzer cancel
- 5 Window wiper
- 6 Window washer



Working mode	Application	Advantage
P	Power mode	<ul style="list-style-type: none"> <li>• Maximum production/power</li> <li>• Fast cycle times</li> </ul>
E	Economy mode	<ul style="list-style-type: none"> <li>• Excellent fuel economy</li> </ul>
B	Breaker mode	<ul style="list-style-type: none"> <li>• Optimum engine RPMs and hydraulic flow</li> </ul>
L	Lifting mode	<ul style="list-style-type: none"> <li>• Hydraulic pressure has been increased by 7%</li> </ul>
ATT	Attachment mode	<ul style="list-style-type: none"> <li>• Optimum engine RPMs, hydraulic flow, 2 way</li> </ul>



### Monitor function

The controller monitors engine oil level, coolant temperature, battery charge and air clogging, etc. If the controller finds any abnormality, it is displayed on the LCD.



### Maintenance function

The monitor indicates when the replacement interval has been reached for the oil and filters.



### Fingertip hydraulic pump oil flow adjustment

From the LCD monitor, you can automatically select the optimal hydraulic pump oil flow for breaking, crushing and other operations in the B, ATT, P or E modes. In addition, the flow to the attachment is automatically reduced during simultaneous operation with other working equipment. This ensures smooth motion of all working equipment.



# ECOLOGY & ECONOMY FEATURES

## Improved fuel consumption



### The new PC210-8 offers up to 10% fuel savings over Dash 7 machines

With its newly developed Komatsu ECOT3 engine, the PC210-8 significantly reduces hourly fuel consumption through highly efficient techniques for matching the engine and hydraulic unit. It also includes a number of features to promote energy-saving operation such as the variable E mode and Eco-gauge.

The Komatsu SAA6D107-1 engine meets EPA Tier III, and EU Stage IIIA emissions regulations and reduces NOx emissions by 29% compared with Dash 7.

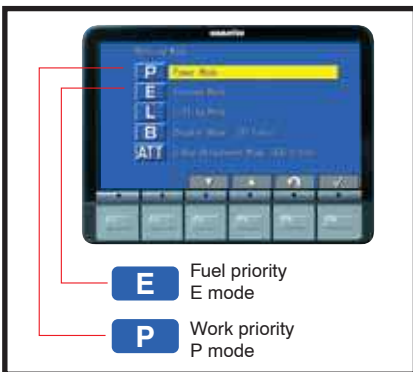

### Working modes

Two established work modes are further improved.

P mode - Power or work priority mode has low fuel consumption, but fast equipment speed, maximum production and power are maintained.

E mode - Economy or fuel priority mode further reduces fuel consumption, but maintains P mode-like working speed for light operations.

You can select Power or Economy modes using a one-touch operation on the monitor panel depending on workload.



### Eco-gauge assists energy-saving operations

The Eco-gauge can be seen on the right hand side of the monitor. Working within the green range for environmentally friendly, energy-saving operations reduces CO<sub>2</sub> emissions and fuel consumption.



### Idle caution

To prevent unnecessary fuel consumption, an idling caution is displayed on the monitor if the engine idles for 5 minutes or more.



## Reduced noise levels

### Low operating noise: -2 dB(A) compared to Dash 7

Reduced noise levels during operation due to low-noise engine and other developments.

- Reduced fan speed (1)
- Large capacity radiator (2)
- Electronically controlled common rail engine (3)
- Multi-staged injection (4)
- Sound insulation cover (5) around low noise muffler (6)
- Optimal arrangement of sound-absorbing materials

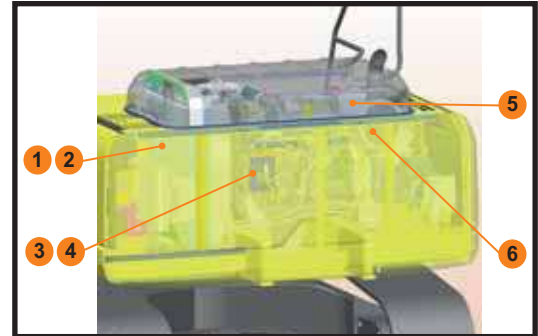

# KOMTRAX™ - KOMATSU TRACKING SYSTEM



The Komatsu Tracking System, KOMTRAX™, provides a revolutionary new way to monitor your equipment, any-time, anywhere. It lets you pin-point the precise location of your machines and obtain real-time machine data. Using GPS transmitter and satellite technology, it's designed to be future proof and will meet your demands today and tomorrow.



KOMTRAX™ server

Check machine location



Customer



Check service meter



Monthly-yearly record

Service & maintenance record

Working levels (fuel, hrs etc)

There are certain countries where KOMTRAX™ is not yet available, please contact your distributor when you want to activate the system. Komtrax will not operate if the satellite signal is blocked or obscured.

# SAFETY FEATURES



### Rear view camera system (optional)

Maximum of 3 cameras, choice of one- or multi-screen.

### Lock lever

Locks the hydraulic pressure to prevent unintentional movement. Neutral start function only allows machine to be started in lock position.



### Anti-slip plates

Highly durable anti-slip plates maintain superior traction performance for the long term.

### Arm safety valve (optional)

(optional)



### Thermal and fan guards

Placed around high-temperature parts of the engine. The fan belt and pulleys are well protected.

### Large side-view, rear, and sidewise mirrors

Enlarged left-side mirror and addition of rear and side mirror allow the machine to meet the new ISO visibility requirements.



### Pump/engine room partition

Prevents hydraulic oil from spraying onto the engine to reduce the risk of fire.



### Reliable components

All of the major machine components (such as the engine, hydraulic pump, hydraulic motor and control valves) are designed and manufactured by Komatsu. This guarantees that each component is expressly built for the class and model of machine. This ensures that the engineering, manufacturing standards and testing that go into each component are 'totally Komatsu'.

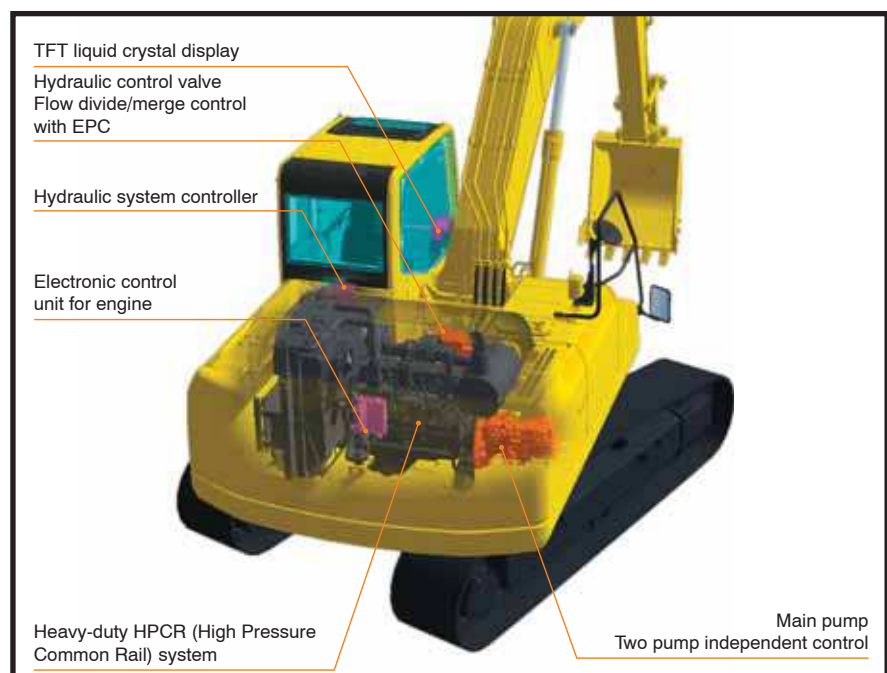

# MAINTENANCE FEATURES

## Side-by-side cooling

Since the radiator, aftercooler and oil cooler are arranged in parallel, it is easy to clean, remove and install them.



## Easy access to the engine oil filter and fuel drain valve

The engine oil filter and fuel drain valve are mounted remotely to improve accessibility.



## Gas-assisted engine hood damper cylinders

The engine hood can be easily opened and closed with help of the gas-assisted engine hood damper cylinders.



## Water separator

This is standard equipment which removes any water that has become mixed with the fuel, preventing fuel system damage.



## Washable floor

The floor is easy to keep clean. The gently inclined surface has a flanged floor mat and drainage holes to facilitate runoff.

## Inclined track frame

The track frame is sloped so that dirt will not accumulate and can be removed easily.

## Long-life oil filters

The hydraulic oil filter uses high-performance filtering material for long element replacement intervals, which significantly reduces maintenance costs.



## Flexible warranty

When you purchase Komatsu equipment, you gain access to a broad range of programmes and services that have been designed to help you get the most from your investment. For example, Komatsu's Flexible Warranty Programme provides a range of extended warranty options on the machine and its components. These can be chosen to meet your individual needs and activities. This programme is designed to help reduce total operating costs.

# SPECIFICATIONS



## ENGINE

Model.....	Komatsu SAA6D107E-1
Type .....	Common rail direct injection, water-cooled, emissionised, turbocharged, after-cooled diesel
Rated capacity.....	110 kW/148 HP (ISO 9249 Net) at engine speed .....
	2.000 rpm
No. of cylinders.....	6
Bore x stroke .....	107 x 124 mm
Displacement.....	6,69 ltr
Battery .....	2 x 12 V/140 Ah
Alternator.....	24 V/60 A
Starter motor .....	24 V/5,5 kW
Air filter type .....	Double element type with monitor panel dust indicator and auto dust evacuator
Cooling .....	Suction type cooling fan with radiator fly screen



## HYDRAULIC SYSTEM

Type .....	HydrauMind. Closed-centre system with load sensing and pressure compensation valves
Additional circuits .....	Depending on the specification up to 2 additional circuits can be installed
Main pump.....	2 variable displacement piston pumps supplying boom, arm, bucket, swing and travel circuits
Maximum pump flow .....	2 x 219 ltr/min
Relief valve settings	
Implement .....	380 bar
Travel .....	380 bar
Swing .....	295 bar
Pilot circuit.....	33 bar



## ENVIRONMENT

Engine emissions .....	Fully complies with EU Stage IIIA and EPA Tier III exhaust emission regulations
Noise levels	
LwA external .....	102 dB(A) (2000/14/EC Stage II)
LpA operator ear .....	69 dB(A) (ISO 6369 dynamic test)



## OPERATING WEIGHT (APPR.)

Operating weight, including 5,7 m one-piece boom, 2,9 m arm, 900 kg bucket, operator, lubricant, coolant, full fuel tank and the standard equipment.



## SWING SYSTEM

Type .....	Axial piston motor driving through planetary double reduction gearbox
Swing lock .....	Electrically actuated wet multi-disc brake integrated into swing motor
Swing speed .....	0 - 12,4 rpm
Swing torque .....	68 kNm
Max. pressure.....	295 bar



## DRIVES AND BRAKES

Steering control .....	2 levers with pedals giving full independent control of each track
Drive method .....	Hydrostatic
Travel operation.....	Automatic 3-speed selection
Gradeability .....	70%, 35°
Max. travel speeds	
Lo / Mi / Hi.....	3,0 / 4,1 / 5,5 km/h
Maximum drawbar pull .....	18.200 kg
Brake system.....	Hydraulically operated discs in each travel motor



## UNDERCARRIAGE

Construction .....	X-frame centre section with box section track frames
Track assembly	
Type .....	Fully sealed
Shoes (each side).....	45 (PC210), 49 (PC210LC/NLC)
Tension.....	Combined spring and hydraulic unit
Rollers	
Track rollers (each side).....	7 (PC210), 9 (PC210LC/NLC)
Carrier rollers (each side) .....	2



## COOLANT AND LUBRICANT CAPACITY (REFILLING)

Fuel tank .....	325,0 ltr
Radiator.....	20,4 ltr
Engine oil.....	23,1 ltr
Swing drive.....	6,6 ltr
Hydraulic tank.....	137,0 ltr
Final drive (each side) .....	3,3 ltr

### MONO BOOM

	PC210-8		PC210LC-8		PC210NLC-8	
	Operating weight	Ground pressure	Operating weight	Ground pressure	Operating weight	Ground pressure
Triple grouser shoes						
500 mm	-	-	-	-	21.830 kg	0,55 kg/cm <sup>2</sup>
600 mm	21.390 kg	0,50 kg/cm <sup>2</sup>	21.990 kg	0,46 kg/cm <sup>2</sup>	22.190 kg	0,47 kg/cm <sup>2</sup>
700 mm	21.640 kg	0,43 kg/cm <sup>2</sup>	22.260 kg	0,40 kg/cm <sup>2</sup>	22.460 kg	0,40 kg/cm <sup>2</sup>
800 mm	21.930 kg	0,38 kg/cm <sup>2</sup>	22.580 kg	0,36 kg/cm <sup>2</sup>	-	-
900 mm	-	-	22.850 kg	0,32 kg/cm <sup>2</sup>	-	-

# MACHINE DIMENSIONS

MACHINE DIMENSIONS		PC210	PC210LC	PC210NLC
A	Overall width of upper structure	2.500 mm	2.500 mm	2.500 mm
B	Overall height of cab	3.035 mm	3.035 mm	3.035 mm
C	Overall length of basic machine	4.810 mm	4.995 mm	4.995 mm
D	Tail length	2.770 mm	2.770 mm	2.770 mm
	Tail swing radius	2.800 mm	2.800 mm	2.800 mm
E	Clearance under counterweight	1.100 mm	1.100 mm	1.100 mm
F	Machine tail height	2.110 mm	2.110 mm	2.110 mm
G	Ground clearance	440 mm	440 mm	440 mm
H	Tumbler centre distance	3.275 mm	3.655 mm	3.655 mm
I	Track length	4.080 mm	4.450 mm	4.450 mm
J	Track gauge	2.200 mm	2.380 mm	2.040 mm
K	Track shoe width	500, 600, 700, 800 mm	600, 700, 800, 900 mm	500, 600, 700 mm
L	Overall track width with 500 mm shoe	2.700 mm	–	2.540 mm
	Overall track width with 600 mm shoe	2.800 mm	2.980 mm	2.640 mm
	Overall track width with 700 mm shoe	2.900 mm	3.080 mm	2.740 mm
	Overall track width with 800 mm shoe	3.000 mm	3.180 mm	–
	Overall track width with 900 mm shoe	–	3.280 mm	–

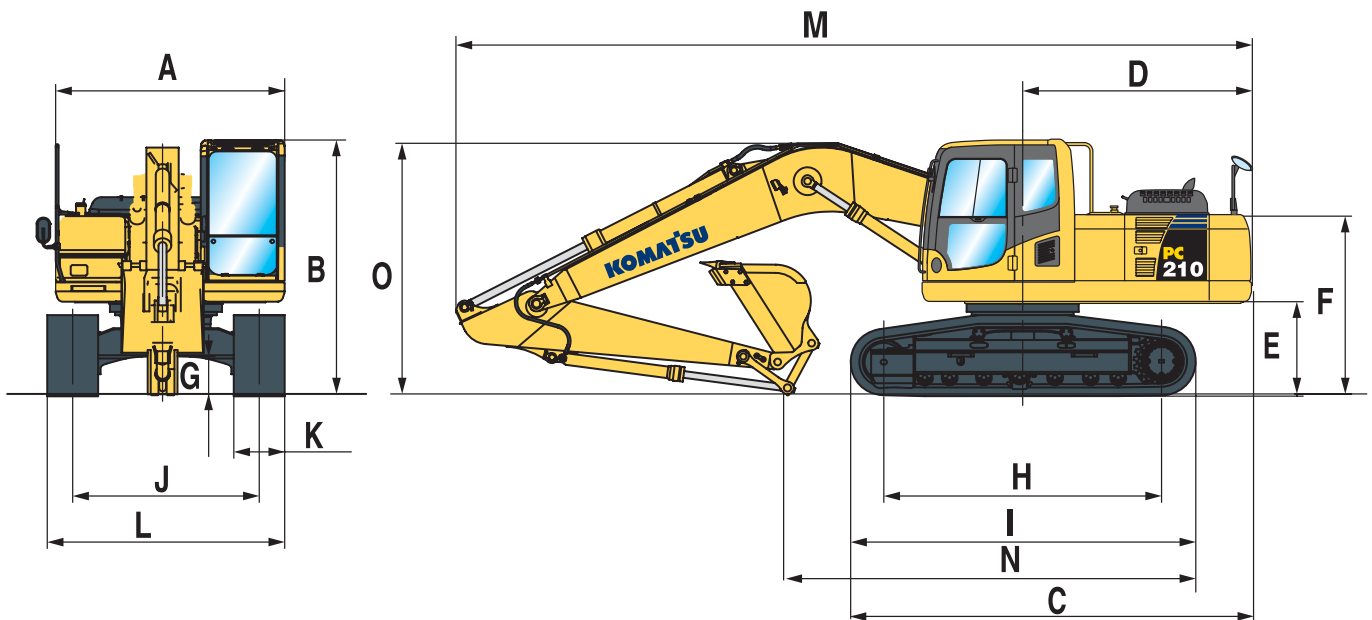

ARM LENGTH		MONO BOOM		
		1,8 m	2,4 m	2,9 m
M	Transport length	9.540 mm	9.555 mm	9.485 mm
N	Length on ground (transport)	PC210 6.270 mm	5.700 mm	4.815 mm
		PC210LC/NLC 6.455 mm	5.885 mm	5.000 mm
O	Overall height (to top of boom)	2.985 mm	3.190 mm	2.970 mm



**BUCKET OPTIONS & DIGGING FORCES**

Specifications and equipment may vary according to regional availability

BUCKET AND ARM COMBINATION			PC210			PC210LC			PC210NLC		
Width	Capacity SAE	Weight	1,8 m	2,4 m	2,9 m	1,8 m	2,4 m	2,9 m	1,8 m	2,4 m	2,9 m
600 mm	0,43 m <sup>3</sup>	570 kg	○	○	○	○	○	○	○	○	○
700 mm	0,52 m <sup>3</sup>	610 kg	○	○	○	○	○	○	○	○	○
800 mm	0,63 m <sup>3</sup>	650 kg	○	○	○	○	○	○	○	○	○
900 mm	0,73 m <sup>3</sup>	690 kg	○	○	○	○	○	○	○	○	○
1.000 mm	0,84 m <sup>3</sup>	740 kg	○	○	○	○	○	○	○	○	○
1.100 mm	0,94 m <sup>3</sup>	820 kg	○	○	○	○	○	○	○	○	○
1.200 mm	1,05 m <sup>3</sup>	850 kg	○	○	○	○	○	○	○	○	○
1.300 mm	1,16 m <sup>3</sup>	880 kg	○	○	○	○	○	○	○	○	○
1.400 mm	1,26 m <sup>3</sup>	950 kg	○	○	○	○	○	○	○	○	□
1.500 mm	1,37 m <sup>3</sup>	1.000 kg	□	□	□	○	○	○	□	□	△
1.600 mm	1,49 m <sup>3</sup>	1.100 kg	□	□	△	□	□	□	△	△	-
1.700 mm	1,58 m <sup>3</sup>	1.150 kg	△	-	-	□	-	-	-	-	-
1.800 mm	1,68 m <sup>3</sup>	1.200 kg	-	-	-	△	-	-	-	-	-

Please consult with your distributor for the correct selection of buckets and attachments to suit the application. The recommendations are given as a guide only, based on typical operating conditions.

- Material weight up to 1,8 t/m<sup>3</sup>
- Material weight up to 1,5 t/m<sup>3</sup>
- △ Material weight up to 1,2 t/m<sup>3</sup>
- Not usable

**A full range of Komatsu wear parts is available.**

A wide range of attachments is available. Please consult your distributor for details of the full range.



BUCKET AND ARM FORCE			
Arm length	1,8 m	2,4 m	2,9 m
Bucket digging force	16.500 kg	16.500 kg	14.100 kg
Bucket digging force at PowerMax	17.500 kg	17.500 kg	15.200 kg
Arm crowd force	13.800 kg	12.200 kg	10.300 kg
Arm crowd force at PowerMax	14.800 kg	13.000 kg	11.000 kg

# WORKING RANGE

## MONO BOOM

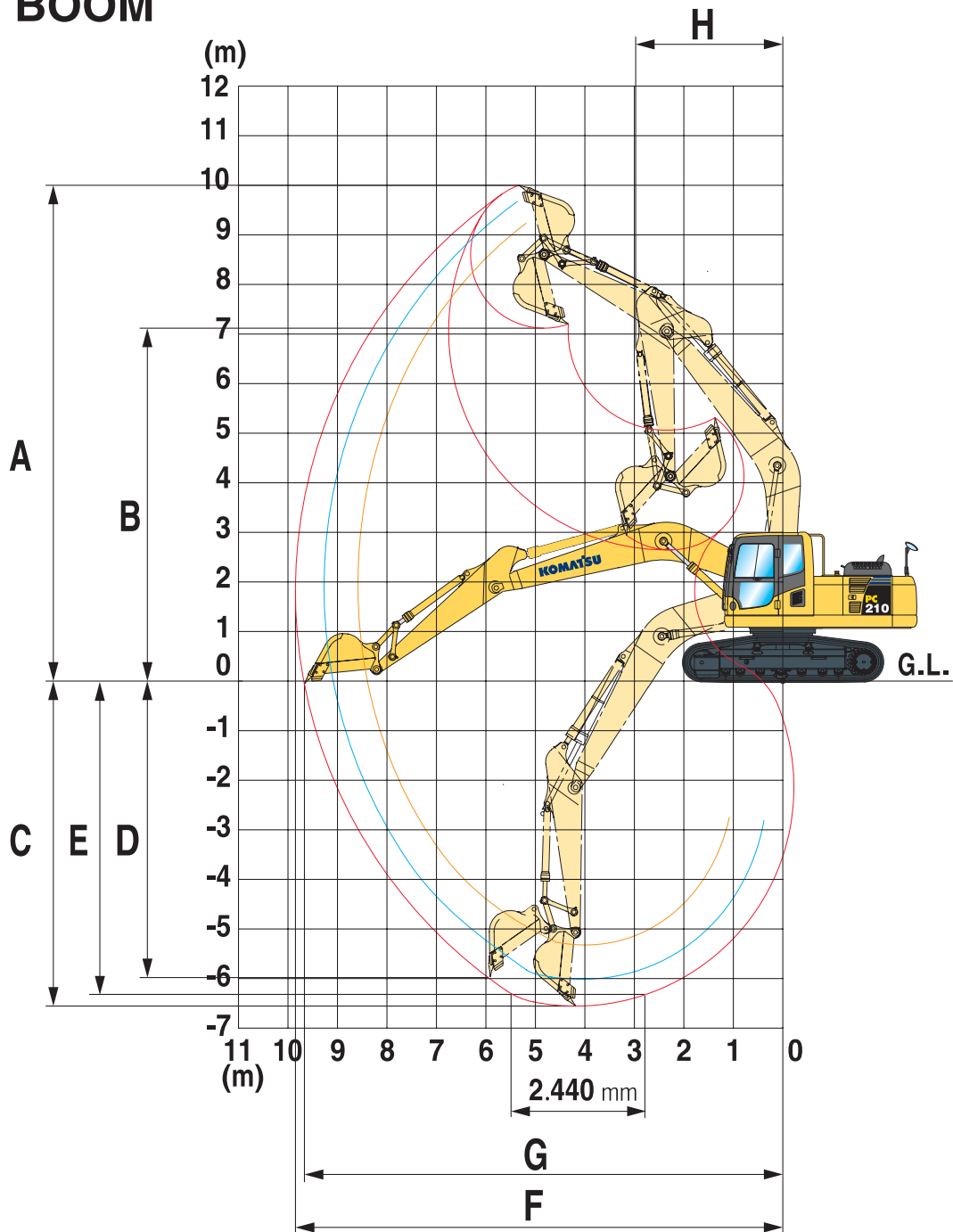

ARM LENGTH		1,8 m	2,4 m	2,9 m
A	Max. digging height	9.500 mm	9.800 mm	10.000 mm
B	Max. dumping height	6.630 mm	6.890 mm	7.110 mm
C	Max. digging depth	5.380 mm	6.095 mm	6.620 mm
D	Max. vertical wall digging depth	4.630 mm	5.430 mm	5.980 mm
E	Max. digging depth of cut for 2,44 m level	5.130 mm	5.780 mm	6.370 mm
F	Max. digging reach	8.850 mm	9.380 mm	9.875 mm
G	Max. digging reach at ground level	8.660 mm	9.190 mm	9.700 mm
H	Min. swing radius	3.010 mm	3.090 mm	3.040 mm



# LIFTING CAPACITY

## PC210-8

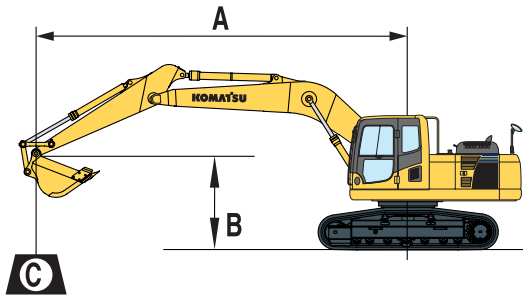

A – Reach from swing centre

B – Bucket hook height

C – Lifting capacities, including bucket (760 kg), bucket linkage (200 kg) and bucket cylinder (140 kg)

When removing bucket, linkage or cylinder, lifting capacities can be increased by their respective weights

With 600 mm shoes

– Rating over front

– Rating over side

– Rating at maximum reach

Arm length	A			7,5 m		6,0 m		4,5 m		3,0 m		1,5 m	

 2,9 m  760 kg	7,5 m	kg	*2.800	*2.800			*4.150	*4.150						
	6,0 m	kg	*2.650	2.600	*3.450	2.800	*4.250	*4.250						
	4,5 m	kg	*2.650	2.150	4.150	2.750	*4.850	4.150	*5.400	*5.400				
	3,0 m	kg	*2.750	1.950	4.000	2.600	*5.800	3.900	*7.350	6.200	*11.450	*11.450		
	1,5 m	kg	2.950	1.850	3.850	2.500	5.550	3.600	8.900	5.600	*6.350	*6.350		
	0,0 m	kg	3.000	1.850	3.700	2.350	5.300	3.400	8.450	5.200	*7.200	*7.200		
	-1,5 m	kg	3.250	2.050	3.650	2.300	5.200	3.250	8.250	5.050	*10.450	9.800	*6.300	*6.300
	-3,0 m	kg	3.900	2.450			5.200	3.250	8.300	5.100	*15.250	10.000	*10.050	*10.050
	-4,5 m	kg	5.400	3.450					8.550	5.300	*12.950	10.450		

 2,4 m  760 kg	7,5 m	kg	*4.150	*4.150										
	6,0 m	kg	*3.950	3.000			*4.750	4.200						
	4,5 m	kg	3.750	2.450	4.050	2.650	*5.350	4.050	*6.200	*6.200				
	3,0 m	kg	3.400	2.200	3.950	2.550	5.800	3.800	*8.050	6.000				
	1,5 m	kg	3.250	2.050	3.800	2.450	5.500	3.550	8.700	5.450				
	0,0 m	kg	3.350	2.100	3.700	2.350	5.300	3.350	8.350	5.150	*6.750	*6.750		
	-1,5 m	kg	3.700	2.350	3.700	2.350	5.200	3.300	8.300	5.100	*11.600	9.900	*7.300	*7.300
	-3,0 m	kg	4.550	2.900			5.250	3.350	8.400	5.150	*14.500	10.200	*12.150	*12.150
	-4,5 m	kg	*6.800	4.450					*8.100	5.450	*11.500	10.700		

 1,8 m  760 kg	7,5 m	kg	*4.950	*4.950									
	6,0 m	kg	*4.550	3.450			*5.450	4.150	*5.750	*5.750			
	4,5 m	kg	4.200	2.750			*5.900	4.000	*7.100	6.450	*10.050	*10.050	
	3,0 m	kg	3.750	2.450	3.950	2.550	5.700	3.750	*8.900	5.800			
	1,5 m	kg	3.600	2.350	3.850	2.450	5.450	3.500	8.550	5.300			
	0,0 m	kg	3.750	2.400	3.800	2.400	5.300	3.350	8.350	5.150			
	-1,5 m	kg	4.200	2.700			5.300	3.350	8.350	5.150	*12.100	10.100	
	-3,0 m	kg	5.400	3.500			5.450	3.500	8.550	5.300	*13.150	10.400	
	-4,5 m	kg											

\* Load is limited by hydraulic capacity rather than tipping.  
Ratings are based on SAE Standard No. J1097.  
Rated loads do not exceed 87% of hydraulic lift capacity or 75% of tipping load.

# LIFTING CAPACITY

## PC210LC-8

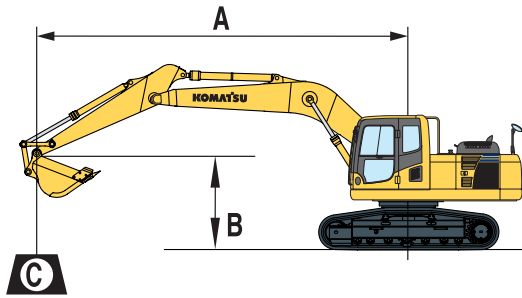

A – Reach from swing centre

B – Bucket hook height

C – Lifting capacities, including bucket (760 kg), bucket linkage (200 kg) and bucket cylinder (140 kg)

When removing bucket, linkage or cylinder, lifting capacities can be increased by their respective weights

With 600 mm shoes

– Rating over front

– Rating over side

– Rating at maximum reach

Arm length	A			7,5 m		6,0 m		4,5 m		3,0 m		1,5 m	

 2,9 m  760 kg	7,5 m	kg	*2.800	*2.800			*4.150	*4.150						
	6,0 m	kg	*2.650	*2.650	*3.450	3.200	*4.250	*4.250						
	4,5 m	kg	*2.650	2.500	*4.550	3.150	*4.850	4.750	*5.400	*5.400				
	3,0 m	kg	*2.750	2.250	4.900	3.050	*5.800	4.450	*7.350	7.100	*11.450	*11.450		
	1,5 m	kg	*3.000	2.200	4.750	2.900	*6.750	4.150	*9.250	6.450	*6.350	*6.350		
	0,0 m	kg	*3.400	2.200	4.600	2.750	6.600	3.950	*10.450	6.050	*7.200	*7.200		
	-1,5 m	kg	4.050	2.400	4.550	2.700	6.450	3.800	10.450	5.900	*10.450	*10.450	*6.300	*6.300
	-3,0 m	kg	4.800	2.900			6.450	3.850	*10.450	5.950	*15.250	11.900	*10.050	*10.050
-4,5 m	kg	*6.300	4.000					*9.000	6.150	*12.950	12.350			

 2,4 m  760 kg	7,5 m	kg	*4.150	*4.150										
	6,0 m	kg	*3.950	3.450			*4.750	*4.750						
	4,5 m	kg	*3.950	2.850	4.950	3.100	*5.350	4.650	*6.200	*6.200				
	3,0 m	kg	4.150	2.550	4.850	3.000	*6.200	4.350	*8.050	6.900				
	1,5 m	kg	4.050	2.450	4.700	2.850	6.750	4.100	*9.800	6.350				
	0,0 m	kg	4.150	2.500	4.600	2.750	6.550	3.900	10.550	6.000	*6.750	*6.750		
	-1,5 m	kg	4.600	2.750	4.600	2.750	6.450	3.850	10.500	5.950	*11.600	*11.600	*7.300	*7.300
	-3,0 m	kg	5.650	3.400			6.550	3.900	*10.150	6.050	*14.500	12.100	*12.150	*12.150
-4,5 m	kg	*6.800	5.150					*8.100	6.300	*11.500	*11.500			

 1,8 m  760 kg	7,5 m	kg	*4.950	*4.950									
	6,0 m	kg	*4.550	3.950			*5.450	4.700	*5.750	*5.750			
	4,5 m	kg	*4.550	3.200			*5.900	4.550	*7.100	*7.100	*10.050	*10.050	
	3,0 m	kg	4.600	2.850	4.800	3.000	*6.700	4.300	*8.900	6.700			
	1,5 m	kg	4.450	2.700	4.700	2.900	6.750	4.100	*10.400	6.200			
	0,0 m	kg	4.600	2.800	4.650	2.850	6.550	3.900	10.550	6.000			
	-1,5 m	kg	5.200	3.150			6.550	3.900	10.550	6.000	*12.100	11.950	
	-3,0 m	kg	6.650	4.050			6.700	4.050	*9.600	6.200	*13.150	12.300	
-4,5 m	kg												

\* Load is limited by hydraulic capacity rather than tipping.  
Ratings are based on SAE Standard No. J1097.  
Rated loads do not exceed 87% of hydraulic lift capacity or 75% of tipping load.

# LIFTING CAPACITY

## PC210NLC-8

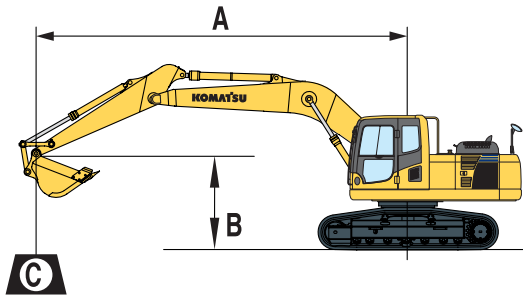

A – Reach from swing centre

B – Bucket hook height

C – Lifting capacities, including bucket (760 kg), bucket linkage (200 kg) and bucket cylinder (140 kg)

When removing bucket, linkage or cylinder, lifting capacities can be increased by their respective weights

With 500 mm shoes

– Rating over front

– Rating over side

– Rating at maximum reach

Arm length	A			7,5 m		6,0 m		4,5 m		3,0 m		1,5 m	

	7,5 m	kg	*2.800	*2.800			*4.150	*4.150						
	6,0 m	kg	*2.650	2.550	*3.450	2.750	*4.250	*4.250						
	4,5 m	kg	*2.650	2.150	*4.550	2.700	*4.850	4.100	*5.400	*5.400				
	3,0 m	kg	*2.750	1.900	4.950	2.600	*5.800	3.800	*7.350	6.050	*11.450	*11.450		
	1,5 m	kg	*3.000	1.800	4.800	2.450	*6.750	3.550	*9.250	5.350	*6.350	*6.350		
	0,0 m	kg	*3.400	1.850	4.650	2.350	6.650	3.300	*10.450	5.100	*7.200	*7.200		
	-1,5 m	kg	4.100	2.000	4.600	2.300	6.500	3.150	10.600	4.800	*10.450	8.800	*6.300	*6.300
	-3,0 m	kg	4.850	2.400			6.550	3.200	*10.450	4.950	*15.250	9.600	*10.050	*10.050
-4,5 m	kg	*6.300	3.400					*9.000	5.150	*12.950	10.000			

	7,5 m	kg	*4.150	4.150										
	6,0 m	kg	*3.950	2.950			*4.750	4.150						
	4,5 m	kg	*3.950	2.450	*4.950	2.650	*5.350	4.000	*6.200	*6.200				
	3,0 m	kg	*4.200	2.150	4.900	2.550	*6.200	3.750	*8.050	5.850				
	1,5 m	kg	4.100	2.050	4.750	2.400	6.850	3.500	*9.800	5.200				
	0,0 m	kg	4.200	2.100	4.650	2.350	6.650	3.300	10.700	5.050	*6.750	*6.750		
	-1,5 m	kg	4.650	2.300	4.650	2.300	6.550	3.200	10.600	4.800	*11.600	8.900	*7.300	*7.300
	-3,0 m	kg	5.700	2.850			6.600	3.300	*10.150	5.050	*14.500	9.750	*12.150	*12.150
-4,5 m	kg	*6.800	4.350					*8.100	5.300	*11.500	10.250			

	7,5 m	kg	*4.950	*4.950									
	6,0 m	kg	*4.550	3.400			*5.450	4.050	*5.750	*5.750			
	4,5 m	kg	*4.550	2.750			*5.900	3.950	*7.100	6.300	*10.050	*10.050	
	3,0 m	kg	4.650	2.400	4.850	2.550	*6.700	3.700	*8.900	5.700			
	1,5 m	kg	4.500	2.300	4.750	2.450	6.800	3.450	*10.400	5.100			
	0,0 m	kg	4.700	2.350	4.700	2.400	6.600	3.300	10.650	5.000			
	-1,5 m	kg	5.250	2.650			6.600	3.250	10.650	4.850	*12.100	9.050	
	-3,0 m	kg	6.750	3.400			6.800	3.450	*9.600	5.200	*13.150	10.000	
-4,5 m	kg												

\* Load is limited by hydraulic capacity rather than tipping.  
 Ratings are based on SAE Standard No. J1097.  
 Rated loads do not exceed 87% of hydraulic lift capacity or 75% of tipping load.

# HYDRAULIC EXCAVATOR

## STANDARD EQUIPMENT

- Komatsu SAA6D107E-1, 110 kW turbocharged common rail direct injection diesel engine, EU Stage IIIA compliant
- Double element type air cleaner with dust indicator and auto dust evacuator
- Suction type cooling fan with radiator fly screen
- Automatic fuel line de-aeration
- Automatic engine warm-up system
- Engine overheat prevention system
- Fuel control dial
- Auto-deceleration function
- Engine key stop
- Alternator 24 V/60 A
- Batteries 2 × 12 V/140 Ah
- Starter motor 24 V/5,5 kW
- Electronic closed-centre load sensing (E-CLSS) hydraulic system (HydrauMind)
- Pump and engine mutual control (PEMC) system
- Multi-function video compatible colour monitor with equipment management monitoring system (EMMS) and efficiency guidance
- 5-working mode selection system; Power mode, economy mode, breaker mode, attachment mode and lifting mode
- PowerMax function
- Standard counterweight
- One additional 2-way proportional service valve (full flow)
- Hydrostatic, 3-speed travel system with automatic shift and planetary gear type final drives, and hydraulic travel and parking brakes
- Adjustable PPC wrist control levers with 3 button controls for arm, boom, bucket and swing
- PPC control levers and pedals for steering and travel
- KOMTRAX™ Komatsu Tracking System
- Reinforced safety SpaceCab™; Highly pressurised and tightly sealed hyper viscous mounted cab with tinted safety glass windows, large roof window with sun shade, pull-up type front window with locking device, removable lower window, front window wiper with intermittent feature, sun roller blind, cigarette lighter, ashtray, luggage shelf, floor mat
- Heated air suspension seat with lumbar support, height adjustable arm rests and retractable seat belt
- Automatic climate control system
- 12 Volt power supply
- Beverage holder and magazine rack
- Hot and cool box
- Radio
- Overload warning device
- Electric horn
- Audible travel alarm
- Track roller guards
- Track frame under-guards
- Lockable fuel cap and covers
- Remote greasing for swing circle and pins
- Fuel supply pump
- Boom safety valves
- Large handrails, rear-view mirrors and counterweight mirror
- Toolkit and spare parts for first service
- Lights; 2 revolving frame lights and 1 boom light
- Engine ignition can be password secured on request
- Standard colour scheme and decals
- Parts book and operator manual

## OPTIONAL EQUIPMENT

- STD, LC and NLC undercarriages
- 500, 600, 700, 800, 900 mm triple grouser track-shoes
- Mono boom
- 1,8 m; 2,4 m; 2,9 m arms
- Additional hydraulic circuits
- Full length track roller guards
- Bucket linkage with lifting eye
- Arm safety valve
- OPG Level II front guard (FOPS)
- OPG Level II top guard (FOPS)
- Service points
- Additional working lamps, including cab roof lights, r.h. boom lamp, counterweight rear lamp and beacon
- Bio oil
- Lower wiper
- Rain visor (not with OPG)
- Rear view camera system
- Komatsu buckets
- Komatsu quick couplers
- Customised paint
- Further equipment on request

Call the experts



**Komatsu Europe International NV**  
 Mechelsesteenweg 586  
 B-1800 VILVOORDE (BELGIUM)  
 Tel. +32-2-255 24 11  
 Fax +32-2-252 19 81  
[www.komatsueurope.com](http://www.komatsueurope.com)

UESS11000 01/2006

Materials and specifications are subject to change without notice.

**KOMATSU** is a trademark of Komatsu Ltd. Japan.