

Mini Dumper

PAYLOAD	1000 kg
GROSS ENGINE POWER	16.4 kW (22 hp)
MAX SKIP CAPACITIES	484 - 725 litres



- Operating payload of 1000 kg.
- 1.5m discharge height - can tip into standard skip.
- Narrow design enables machines to pass through a standard 1m doorway (HD1000 only when fitted with optional narrow tyres).
- "Rental Tough" designs and fabrications to keep you working in tough conditions.
- Exceptional service access and ease of maintenance built into every machine.
- High ground clearance to cope with difficult ground conditions.
- Low centre of gravity for superb stability.
- Hydrostatic transmissions for additional hill-climbing power.

Technical Data

	HD1000
Payload (kg)	1000
Unladen Weight (kg)	1440
Skip Capacity - Water (ltr)	338
- Struck (ltr)	446
- Heaped (ltr)	577
Engine	Kubota D905
Gross Power - kW (hp)	16.4 (22.0) @ 3000 RPM
Tyre Size	7.00 x 12 (opt.) 10.0/75x15.3
Drive	Hydrostatic
Max Travel Speed (kph)	11.0

Mini Dumper HD1000

Dimensions

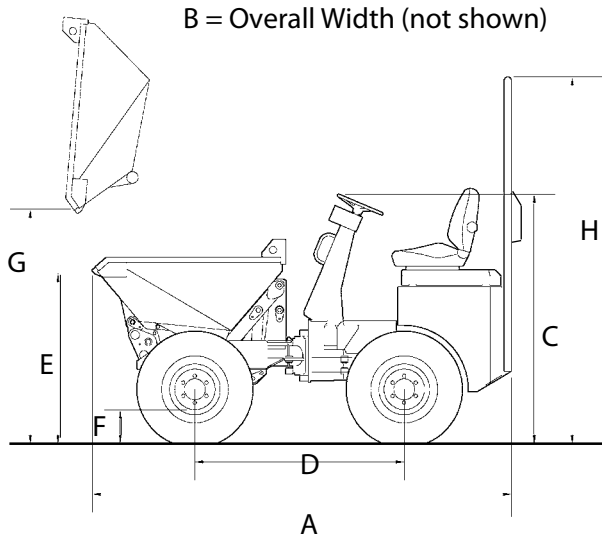

Dimensions (mm)		HD1000		
A	Total Length	2959		
B	Total Width	998* / 1120		
C	Height to Top of Steering Wheel	1745		
D	Wheelbase	1440		
E	Height to Front Lip of Skip (lowered)	1175		
F	Ground Clearance	241		
G	Height to Front Lip of Skip (discharged)	1595		
H	Height to Top of ROPS (raised)	2483		

* When fitted with optional narrow tyres.

Standard Equipment & Options

Standard Equipment

- Folding ROPS frame
- Reversing Alarm
- Beacon
- 10.0/75x15.3 Tyres

Optional Equipment

- Site Lights
- Road Lights (RTA)
- Narrow Tyres (700 x 12)
- Rear View Mirror
- Grassland Tyres

Capacities

	HD1000
Fuel Tank	42 Litres
Hydraulic Tank	27 Litres

Systems

	HD1000
Hydraulic	24 l/min, 130 bar
Braking	Hydrostatic Dynamic



TEREX Construction
Central Boulevard, ProLogis Park,
Coventry, England CV6 4BX

www.terex.com

PHONE ++44 (0) 2476 339400
FAX ++44 (0) 2476 339500
EMAIL enquiries@terexce.com
WEB www.terexce.com



PJP [UK] Limited
Mill Street, Radcliffe
Manchester M26 1AJ, England

TEL 0161 959 0000 FAX 0161 959 1111
E-MAIL hire@pjpuk.com WEB www.pjpuk.com

For further information, please contact your local distributor or the Terex sales office listed. Terex pursues a policy of continuous development for its products. Product specifications are subject to change without notice or obligation. The photographs and drawings in this brochure are for illustrative purposes only. Refer to the appropriate Operator's Manual for instructions on the proper use of this equipment. Failure to follow the appropriate Operator's Manual when using our equipment or to otherwise act irresponsibly may result in serious injury or death. Prices and specifications subject to change without notice. The only warranty applicable is the standard written warranty applicable to the particular product and sale. Terex makes no other warranties, whether expressed or implied. Products and services listed may be trademarks, service marks or trade-names of Terex Corporation and/or its subsidiaries in the USA and other countries and all rights are reserved. "Terex" is a Registered Trademark of Terex Corporation in the USA and many other countries. Copyright ©09.2006 Terex Corporation

DS HD 0107-EN

