

# SITE DUMPER



## Specifications

Payload	13,228 lbs (6,000 kg)
Gross Engine Power	84 hp (62.5 kW)
Max Skip Capacity	4.9 yds (3,780 liters)

## Features

- Large heaped skip capacity.
- “Rental Tough” designs and fabrications to keep you working in the toughest conditions.
- Thick steel skip base plate with reinforced box sections for high strength and longevity.
- Exceptional service access and ease of maintenance built into every machine.
- High ground clearance, low center of gravity for superb stability and site accessibility.
- Powerful, reliable and economical engines.
- Power Swivel enables effective placement of load to either side — useful for trench filling or small sites.

**WORKS FOR YOU.™**

# SPECIFICATIONS

## Performance

	TA6	TA6s
Payload lb (kg)	13,228 (6000)	13,228 (6000)
Unladen Weight (kg)	9060 (4110)	9414 (4270)
Skip Capacity - Water ft <sup>3</sup> (ltr)	2.55 (1950)	2.40 (1850)
Struck yd (ltr)	3.58 (2740)	3.60 (2750)
Heaped yd <sup>3</sup> (ltr)	4.94 (3780)	4.60 (3520)
Engine	Perkins 1104D-44T	Perkins 1104D-44T
Gross Power hp (kW)	62.5 (84 hp) at 2200 rpm	62.5 (84 hp) at 2200 rpm
Displacement	4.4 liters (4400 cc)	4.4 liters (4400 cc)
Maximum Torque	353 Nm at 1400 rpm	353 Nm at 1400 rpm
Tire Size	405/70-20-14PR	405/70-20-14PR
Drive	4/4 Powershuttle - permanent 4WD	4/4 Powershuttle - permanent 4WD
Max Travel Speed - mph (kph)	16.8 (27.0)	16.8 (27.0)
Gradeability	25%	25%
Fuel Tank Capacity	17.7 gals (67 liters)	17.7 gals (67 liters)
Hydraulic Tank Capacity	13 gals (50 liters)	13 gals (50 liters)

## Hydraulic System (Gear Pump)

	TA6	TA6s
Flow rate		
Operating Pressure		

## Hydraulic System (Gear Pump)

	TA6	TA6s
Working Brake	Foot Brake - oil immersed discs on front/rear	
Parking Brake	Ratchet parking brake - dry disc (gearbox)	

## Hydraulic System (Gear Pump)

	TA6	TA6s
Voltage	12V	12V
Battery	90 Ah	90 Ah
Alternator	95 A	95 A

B = Overall Width (not shown)

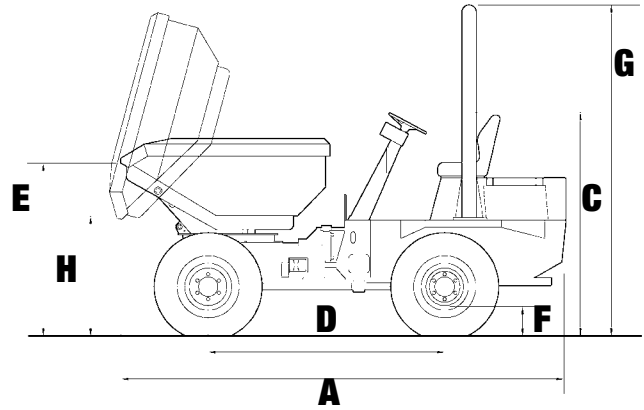
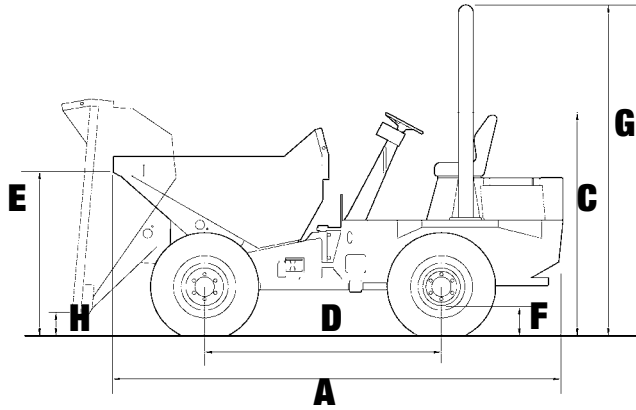

## Dimensions

	TA6	TA6s
A Total Length	14.2 ft (4320 mm)	15.1 ft (4590 mm)
B Total Width (not shown)	92.5 (2350 mm)	82.5 (2095 mm)
C Height to Top of Steering Wheel	85 in (2160 mm)	85 in (2160 mm)
D Wheelbase	96.5 in (2450 mm)	96.5 in (2450 mm)
E Height to Front Lip of Skip (untipped)	64.2 in (1630 mm)	69.3 in (1760 mm)
F Ground Clearance	15 in (380 mm)	15 in (380 mm)
G Height to Top of ROPS (raised)	114.6 in (2910 mm)	114.6 in (2910 mm)
H Height to Front Lip of Skip (tipped)	14.2 in (360 mm)	43.3 in (1100 mm)
Turning Radius to Outside of Skip	18.4 ft (5600 mm)	18.4 ft (5600 mm)
Steering Angle	+/- 30°	+/- 30°
Oscillation	+/- 10.5°	+/- 10.5°
Tipping Type	Forward Tip	Swing Tip

## Standard Equipment

Folding ROPS Frame	Reversing Alarm
Flashing Beacon	Towing Bracket

## Optional Equipment

Road Lights (RTA)	Rear View Mirror
Site Lights	Special Paint

**terex.com**

Effective Date: May 2010. Product specifications and prices are subject to change without notice or obligation. The photographs and/or drawings in this document are for illustrative purposes only. Refer to the appropriate Operator's Manual for instructions on the proper use of this equipment. Failure to follow the appropriate Operator's Manual when using our equipment or to otherwise act irresponsibly may result in serious injury or death. The only warranty applicable to our equipment is the standard written warranty applicable to the particular product and sale and Terex makes no other warranty, express or implied. Products and services listed may be trademarks, service marks, or trade names of Terex Corporation and/or its subsidiaries in the USA and other countries. All rights are reserved. Terex is a registered trademark of Terex Corporation in the USA and many other countries. © 2010 Terex Corporation.

8800 Rostin Road, Southaven, MS 38671 USA  
1.888.90.TEREX (83739)



**WORKS FOR YOU.™**  
TAG/TAGs 0510 PN 127807